

## APPLICATIONS

- Long - range passive motion detectors, for use in alarm systems inside buildings and outdoors.
- **Very small detection angle of only 0.66°** for use as a curtain sensor into combination with fence systems.

## FEATURES

- **Large vertical detection area**; 100% coverage of the detection area due to the use of an internal system of mirrors.
- Detects even extremely slow movement (0.2 m/s) at right angles to the detection axis.
- In the operating position shown below, with the upper edge of the vertical detection area horizontal (as is usual), the actual telescope SPI 106 is tilted downwards by 30°. This makes it **difficult for intruders to estimate the real detection area**.

Passive IR detection is based on the recording of changes in the continuously measured background temperature.

The high-quality precision optical system with an integrated system of mirrors picks up the thermal radiation and focuses it on a dual pyro-electrical sensor.

Temperature changes caused by objects moving across the detection axis

or towards the detector are evaluated and used for triggering an alarm.

The evaluation electronics provide a high degree of safety against false alarms due to changing weather conditions, such as sudden temperature changes, the onset of precipitation or gusts of wind.

The telescopes are designed for indoor or outdoor use.

## Passive Infrared Telescope SPI 106

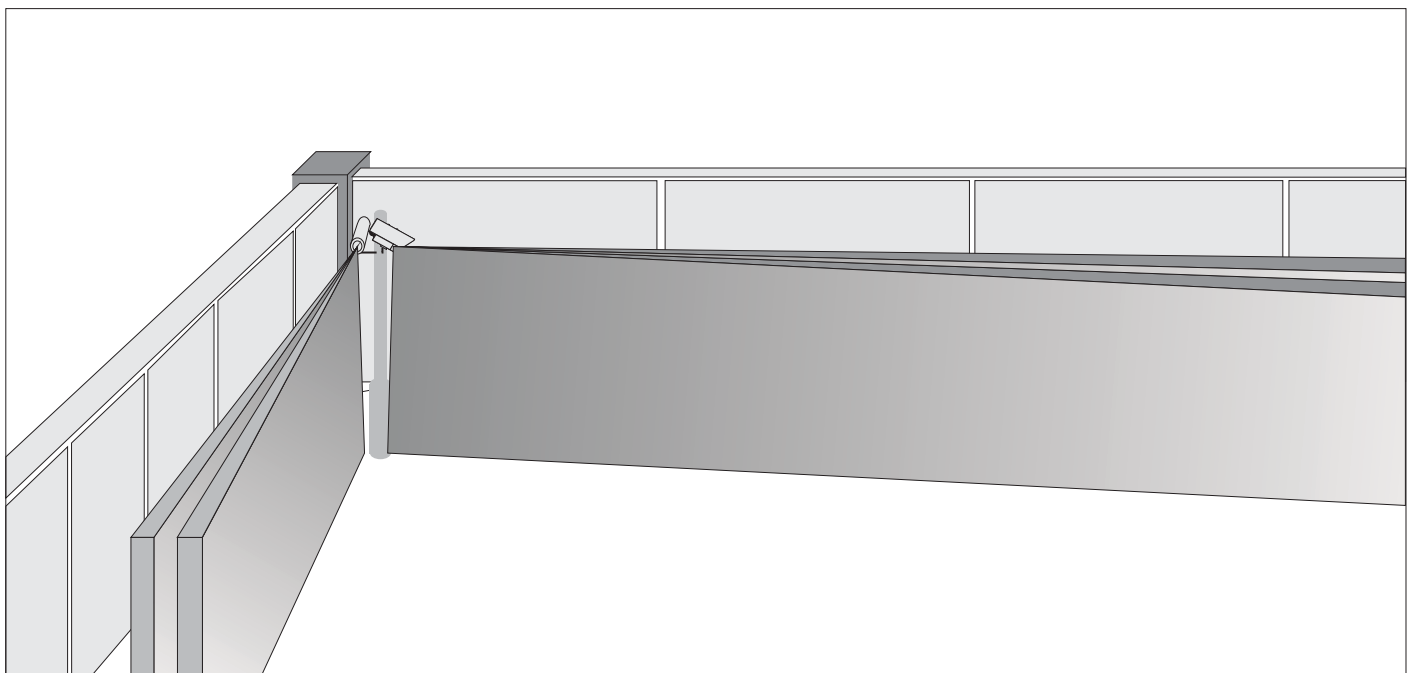

# PASSIVE INFRARED TELESCOPES

Brief descriptions and data sheets

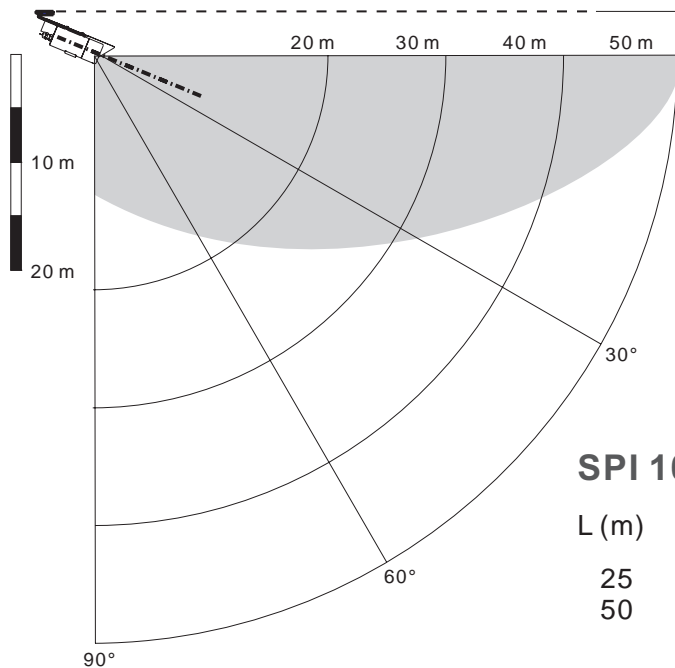

The aiming line of the aiming device delimits the upper edge of the detection area

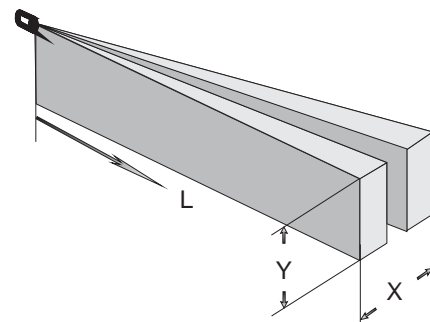

## SPI 106

see (1)

L (m)	X (m)	Y (m)
25	0,3	4,5
50	0,6	4,5

## TECHNICAL DATA SPI 106

Nominal range	50 m
Monitored spatial angle	
- vertical:	max. 90°
- horizontal:	0,66°
Spectral sensitivity:	8 - 14 µm
Supply voltage:	12 V DC +/- 25 %
Power consumption:	0,25 W
- with heater:	1,25 W
Alarm output:	potential-free relay contact (normally open/normally closed) serial resistor 10 Ohm
Delay between power-on and ready for operation:	approx. 50 s
Connection:	permanently mounted cable, length 6 m (7 x 0.34 mm <sup>2</sup> )
Ambient temperature:	- 25 up to + 65°C
Case:	degree of protection IP 66, anodised aluminium
Dimensions - L:	200 mm
- W:	85 mm
- H:	80 mm

(1) The detection ranges shown above are for an installation height of 4.5 m. They can be utilised within the entire vertical detection angle of 45° or 85°

## ORDERING INFORMATION

SPI 106	Passive-IR-Telescope; vertical aperture 90°
SPI 106-A (Optional)	Passive-IR-Telescope; A-vertical aperture in degree
SPI V	Aiming device for SPI 104, SPI 105 and SPI 106
SPI W	Wall mounting

